

TIME

ELECTRONIC

ACCURATE

MACHINERY

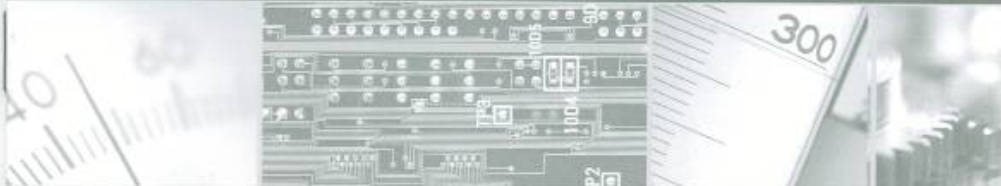

Operation Manual

# **ELECTRONIC TIME RECORDER**

# **NEEDEK TM920**

COMPACT

PERFORMANCE

RELIABILITY

# CONTENTS

<b>1.INTRODUCTION</b>	1
<b>2.NOMENCLATURE</b>	1
<b>3.COMPONENTS</b>	2
<b>4.BEFORE OPERATION</b>	
4.1 Power Source .....	3
4.2 Opening the Lid .....	3
<b>5.SETTING</b>	
5.1 Setting year .....	3
5.2 Setting date .....	3
5.3 Setting time .....	4
5.4 Setting Day Line Change time .....	4
5.5 Setting card format .....	5
5.6 Setting time card & Pay period .....	5
5.7 Setting hours mode .....	6
5.8 Setting printing position .....	6
5.9 Setting Daylight Saving Time .....	7
5.10 Setting printing format .....	8
5.11 Setting function for auto-detecting time card .....	9
<b>6.SETTING FOR PRINTING COLOR</b>	9
<b>7.SETTING MUSIC/OUTPUT</b>	10
<b>8.SETTING COLUMN FOR PRINTING POSITION</b>	11
<b>9.INSERT A TIME CARD</b>	12
<b>10.MAINTENANCE</b>	
10.1 Replacing Ribbon Cassette .....	13
10.2 Lithium Battery .....	13
<b>11.DIAGNOSIS OF ERROR CODE</b>	13
<b>12.CAUTION</b>	14
<b>13.SPECIFICATION</b>	14

## INTRODUCTION

The TM series of time recorder are designed with compact size to achieve Hi-End technology as your expectation. It also provides superior performance and extent of our reliabilities. Before to operate this unit, please read this manual carefully and keep it for future maintenance or next setting in case of change.

### LIST OF MODELS

MODEL	TM900	TM920	TM700	TM720
TWO COLORS	⊙	⊙	⊙	⊙
MUSIC/OUTPUT	⊙	⊙	⊙	⊙
BACKUP BATTERY		⊙		⊙

## NOMENCLATURE

### ■ Setting Keys ■

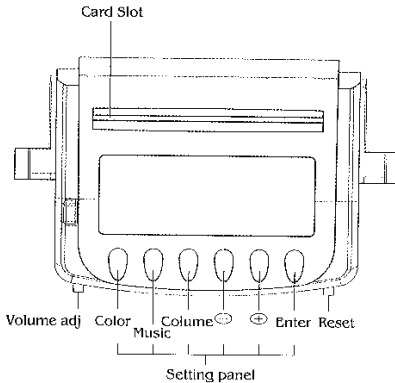

### ■ Liquid Crystal Display ■

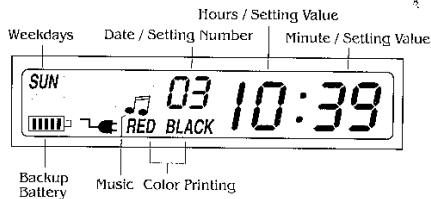
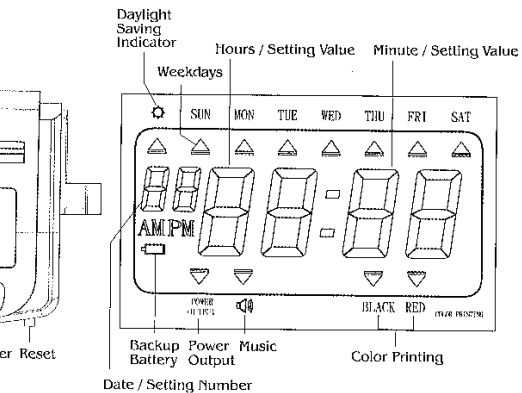

## COMPONENTS

900 series

time recorder

operation manual

keys

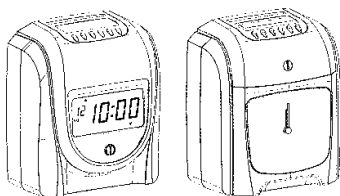

Name of parts

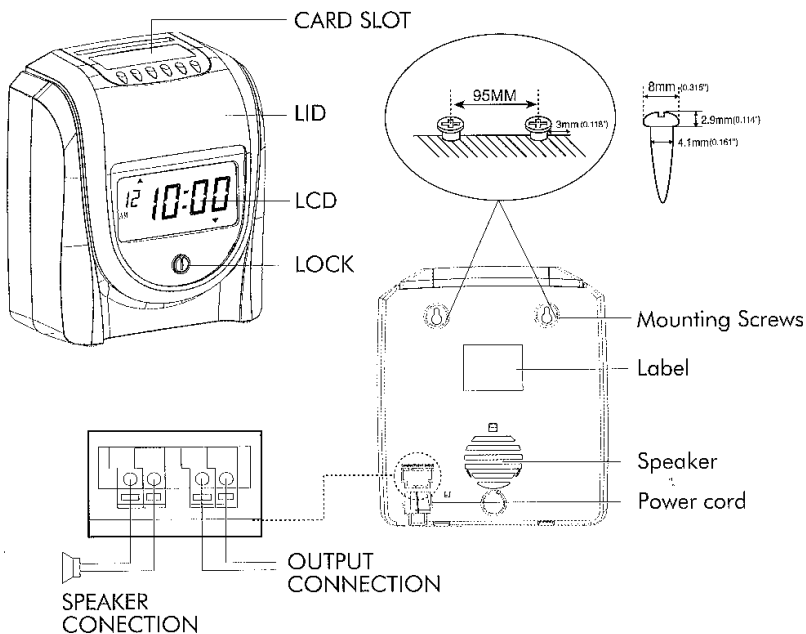

## BEFORE OPERATION

### 4.1 Power SOURCE

Plug the unit to continuous and correct voltage of power source. (refer to voltage indication on the label of each machine)

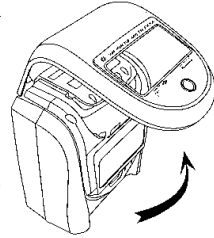

### 4.2 OPENING THE LID

Insert the key in the cover lock, unlock and remove the cover.

## SETTING

Open the lid to enter the setup mode.

### 5.1 SETTING YEAR

1. In the setting mode, press the  $\oplus$   $\ominus$  button to choose setting number 01 on left of display.
2. Press the ENTER button to enter year setting.
3. Press  $\oplus$   $\ominus$  to select the correct year.
4. Press ENTER button to confirm setting.
5. The setting number now turns to 02.
6. To continue next set of setting or close the lid to complete and exit setting.

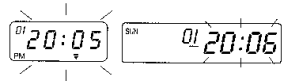

### 5.2 SETTING DATE

1. In the setting mode, press the  $\oplus$   $\ominus$  button to choose setting number 02 on left of display.
2. Press the ENTER button to enter date setting.
3. Press  $\oplus$   $\ominus$  to select the correct month.
4. Press ENTER button to confirm setting.



5. Press  $\oplus$   $\ominus$  to select the correct date.
6. Press ENTER button to confirm setting.
7. The setting number now turns to 03.
8. To continue next set of setting or close the lid to complete and exit setting.

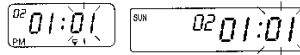

### 5.3 SETTING TIME

1. In the setting mode, press the  $\oplus$   $\ominus$  button to choose setting number 03 on left of display.
2. Press the ENTER button to enter time setting.
3. Press  $\oplus$   $\ominus$  to select the correct hour.
4. Press ENTER button to confirm setting.
5. Press  $\oplus$   $\ominus$  to select the correct minute.
6. Press ENTER button to confirm setting.
7. Press  $\ominus$  button to zero the second.
8. Press ENTER button to confirm setting.
9. The setting number now turns to 04.
10. To continue next set of setting or close the lid to complete and exit setting.



### 5.4 SETTING DAY LINE CHANGE TIME

1. In the setting mode, press the  $\oplus$   $\ominus$  button to choose setting number 04 on left of display.
2. Press the ENTER button to enter setting.
3. Press  $\oplus$   $\ominus$  to select the desired Day Line Change hour. (origin setting 00:00)
4. Press ENTER button to confirm setting.
5. Press  $\oplus$   $\ominus$  to select the desired Day Line Change minute.
6. Press ENTER button to confirm setting.
7. The setting number now turns to 05.
8. To continue next set of setting or close the lid to complete and exit setting.

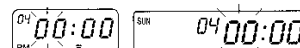
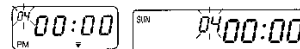

## 5.5 SETTING CARD FORMAT

1. In the setting mode, press the  $\oplus$   $\ominus$  button to choose setting number 05 on left of display.

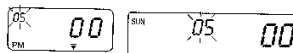

2. Press the ENTER button to enter setting.

3. Press  $\oplus$   $\ominus$  to select the desired time card format.



00-the 1st row blank (standard time card)

01-the 16th row blank.

4. Press ENTER button to confirm setting.

5. The setting number now turns to 06.

6. To continue next set of setting or close the lid to complete and exit setting.

## 5.6 SETTING TIME CARD & PAY PERIOD

1. In the setting mode, press the  $\oplus$   $\ominus$  button to choose setting number 06 on left of display.



2. Press the ENTER button to enter setting.

3. Press  $\oplus$   $\ominus$  button to select 00/01/02 for time card type.



\*00-the monthly pay of time card.

\*01-the weekly pay of time card.

\*02-the Bi-weekly pay of time card.

※ Please choose the one of card type which is applied to the user, and make a proper setting to the card type number corresponding to each sample card below.

A. If 01/02 has been chosen, the display will turn to weekdays setting.

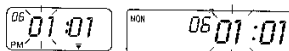

B. Press  $\oplus$   $\ominus$  button to select one of weekdays for pay period ending day.



C. For weekly card there are three types of time card for setting 00/01/02.

D.To choose the printing for day of the week 00/01/02(00:Date, 01:Day number, 02: English)

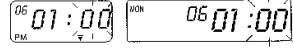

E.For bi-weekly card the current week first (01)/second(02)for setting.



- 4.Press ENTER button to confirm setting.
- 5.The setting number now turns to 07.
- 6.To continue next set of setting or close the lid to complete and exit setting.

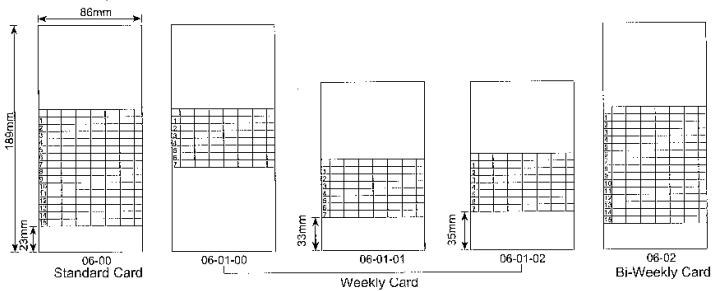

### 5.7 SETTING HOURS MODE

1. In the setting mode, press the  $\oplus$   $\ominus$  button to choose setting number 07 on left of display.



2.Press the ENTER button to enter hours mode.

3.Press  $\oplus$   $\ominus$  to select the desired hours mode.

- 12-12 hours mode (EX.PM 1:00=13:00)
- 24-24 hours mode



4.Press ENTER button to confirm setting.

5.The setting number now turns to 08

6.To continue next set of setting or close the lid to complete and exit setting.

### 5.8 SETTING PRINTING POSITION

1. In the setting mode, press the  $\oplus$   $\ominus$  button

- to choose setting number 08 on left of display.
2. Press the ENTER button to enter setting.
3. Press  $\oplus \ominus$  to select the desired vertical printing position setting.



\*The number between 00-15, the number building up the printing position will move to upper of row.



4. Press ENTER button to confirm setting.
5. Press  $\oplus \ominus$  to select the desired horizontal printing position setting.
- \*The number between 00-30, the number building up the printing position will move to the right of column.



6. Press ENTER button to confirm setting.
7. The setting number now turns to 09
8. To continue next set of setting or close the lid to complete and exit setting.

## 5.9 SETTING DAYLIGHT SAVING TIME

1. In the setting mode, press the  $\oplus \ominus$  button to choose setting number 09 on left of display.



2. Press the ENTER button to enter setting.



3. Press  $\oplus \ominus$  to select the current year.
4. Press ENTER button to confirm setting.
5. Press  $\oplus \ominus$  to select beginning month for Day Light Saving time.



6. Press ENTER button to confirm setting.
7. Press  $\oplus \ominus$  to select the beginning date for Day Light Saving time.



8. Press ENTER button to confirm setting.
9. Press  $\oplus \ominus$  to select the beginning hours for Day Light Saving time.



10. Now display turns to the ending date for Day Light Saving time.

11. Press  $\oplus$   $\ominus$  to select ending month for Day Light Saving time.



12. Press ENTER button to confirm setting.



13. Press  $\oplus$   $\ominus$  to select the ending date for Day Light Saving time.

14. Press ENTER button to confirm setting.

15. Press  $\oplus$   $\ominus$  to select ending hours for Day Light Saving time.



16. Press ENTER button to confirm setting.

17. The setting number now turns to 10.

18. To continue next set of setting or close the lid to complete and exit setting.

PS. At the time of Day Light Saving that will be automatically advancing one hour and at ending time will go back to origin time.

To malfunction this setting by setting month with 00.

### 5.10 SETTING PRINTING FORMAT

1. In the setting mode, press the  $\oplus$   $\ominus$  button to choose setting number 10 on left of display.



2. Press to ENTER button to enter setting.

3. Press  $\oplus$   $\ominus$  to select the desired printing mode.

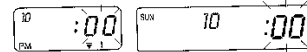

\*00-24 hours printing mode (1/60 hour)

\*01-centennial printing mode (1/100 hour)

\*02-12 hours printing mode

Ex. 01:00 (=PM13:00)

4. Press ENTER button to confirm setting.

5. The setting number now turns to 11

6. To continue next set of setting or close the lid to complete and exit setting.

### 5.11 SETTING FUNCTION FOR AUTO- DETECTING TIME CARD

1. In the setting mode, press the  $\oplus \ominus$  button to choose setting number 11 on left of display.



2. Press to ENTER button to enter setting.

3. Press  $\oplus \ominus$  to select the 00/01

\*00-With function for auto-detecting time card.

\*01-Without function for auto-detecting time card.



4. Press ENTER button to confirm setting.

5. To select COLOR/MUSIC/COLUMN button to function setting.

### SETTING FOR PRINTING COLOR

1. In th setting mode, press COLOR button to enter printing color setting.



2. Press ENTER to hours setting.

3. Press  $\oplus \ominus$  to select hours for color change.

4. Press ENTER button to confirm setting.

5. Press  $\oplus \ominus$  to select desired minute for color change.



6. Press ENTER button to confirm setting.

7. Press  $\oplus \ominus$  to select 01/02 for color print.

· 01-for black color print

· 02-for red color print



8. Press ENTER button to confirm setting.

9. Now display turns to weekdays setting.

PS. If weekdays are not necessary to be set, press ENTER button to skip step 10-13

10. Press  $\oplus \ominus$  to select weekdays, if the weekday is chosen the ▲ sign will be flashing on the top of display.



11. Press COLOR button once to delete selected weekday for color print. (press COLOR button again to show the ▲ sign)
12. Press (+) (-) to move ▲ sign, and COLOR button to register weekdays for color print.
13. After completing weekdays setting, press ENTER button to confirm setting.
14. Now the setting number turns to 02, repeat step 2-13 to continue next set of setting or close the lid to complete and exit setting.

## SETTING MUSIC / OUTPUT

1. In the setting mode, press MUSIC button to enter music/output setting.
2. Press ENTER to hours setting.
3. Press (+) (-) to select desired hours for music/output.
4. Press ENTER button to confirm setting.
5. Press (+) (-) to select desired minute for music/output.
6. Press ENTER button to confirm setting.
7. Press (+) (-) to select 01/02 or 03 for music/output setting.
  - 01-internal music bell
  - 02-external bell alarm output
  - 03-music bell & external bell alarm output.
8. Press ENTER button to confirm setting.
9. Press (+) (-) to select duration for signal output.
  - Origin setting-00:22(22 seconds)
  - Maximum duration-59 min. 59 sec.
10. Press ENTER button to confirm setting.

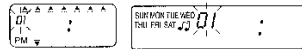

11. Now display turns to weekdays setting.  
PS.If weekdays are not necessary to be set, press ENTER button to skip step 12-15
12. Press  $\oplus$   $\ominus$  to select weekdays, if the weekdays chosen the ▲ sign will be flashing on the top of display.
13. Press MUSIC button once to delete selected weekday for music/output. (press MUSIC button again to show ▲ sign)
14. Press  $\oplus$   $\ominus$  to move ▲ sign, and MUSIC button to register weekdays for music/output.
15. After completing weekdays setting, press ENTER button to confirm setting.
16. Now the setting number turns to 02, repeat step 2-16 continue next set of setting or close the lid to complete and exit setting.

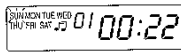
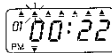

## SETTING COLUMN FOR PRINTING POSITION

1. In th setting mode, press COLUMN button to enter column setting.
2. Press ENTER to hours setting.
3. Press  $\oplus$   $\ominus$  to select desired hours for column print.
4. Press ENTER button to confirm setting.
5. Press  $\oplus$   $\ominus$  to select desired minute for column print.
6. Press ENTER button to confirm setting.
7. Press  $\oplus$   $\ominus$  to select column 01-06 for print.
8. Press ENTER button to confirm setting.
9. Now display turns to weekdays setting.  
PS.If weekdays are not necessary to be set, press ENTER button to skip step 10-13.

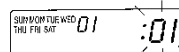
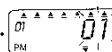
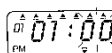
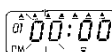
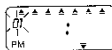

10. Press  $\oplus$ / $\ominus$  to select weekdays, if the weekday is chosen the ▲ sign will be flashing on the top of display.
11. Press COLUMN button once to delete selected weekday for column print. (press COLUMN button again to show the ▲ sign)
12. Press  $\oplus$ / $\ominus$  to move ▲ sign, and COLUMN button to register weekdays for column print.
13. After completing weekdays setting, press ENTER button to confirm setting.
14. Now the setting number turns to 02, repeat step 2-13 to continue next set of setting or close the lid to complete and exit setting.



### How to delete a setting ?

Press  $\oplus$ / $\ominus$  button to select the setting number on the left of display, then press  $\oplus$  and ENTER button simultaneously for 3 seconds to delete that set of setting.

### INSERT A TIME CARD

1. Insert a time card with correct side into card slot carefully. (If you insert a wrong side of time card it will be rejecting from this unit without being printed, and displaying error code on display)
2. Time card will be automatic fed and printed on the column of position that correspond to one lit button on the top. After print, time card will pull out from card slot automatically.

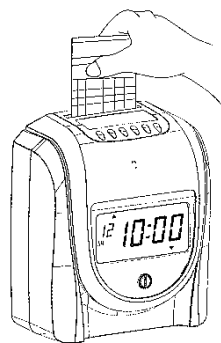

## MAINTENANCE

### 10.1 Replacing Ribbon Cassette

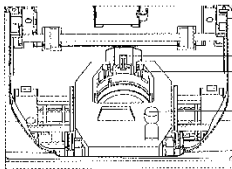
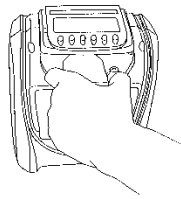
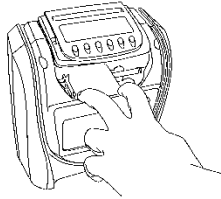
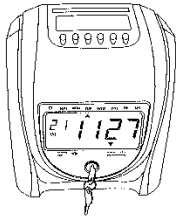

Ribbon guide  
Printer  
Knob

Always tight the ribbon by turning the knob after replacing ribbon cassette.

### 10.2 Lithium Battery

The time recorder build-in a lithium battery on PC board to keep the correct time and programming for 3 years of simulate power failure hours. Always plug the unit to the correct outlet or replacing the battery after is malfunction.

#### CAUTION

Donger of explosion if battery is incorrectly replaced. Replace only with the same or equivalent type recommended by the manufacturer. Dispose of used batteries according to the manufacturer's instructions.

## DIAGNOSIS OF ERROR CODE

01	Insert wrong side of time card.
02	Motor for card inserting.
03	Motor for printer head.
04	Key button.

## CAUTION

- 1.The unit can be only indoor use. Do not install them outdoors or where they are exposed to rain or in a location near heat radiators or air dusts out let \ moisture \ rain \ mechanical shock vibration.
- 2.Always plug the unit the correct source.
- 3.Should not any liquid or solid object fall into the unit.
- 4.Do not operate this unit with a damaged cord or plug of after the unit malfunction, or damaged in any manner.
- 5.Return the unit to authorized service facility for examination, repair or adjustment.
- 6.Unplug the unit and have it check be qualified personal before operate the unit any further.
- 7.For PLUGGABLE EQUIPMENT, that the socket-outlet shall be installed near the equipment and shall be easily accessible.

## SPECIFICATION

POWER RATIONG	110-120V ( or 220-240V ) (refer to the voltage indication on the label of each machine)
AMP	0.22Amp
DIMENSION	10.5 X 19 X 22.5 cm <sup>3</sup> (D x W x H)
WEIGHT	2.0 KGS
AMBIENT	0°C-40°C
CONDITION	10-80% RH
STANDARD TIME CARD	86mmx189mm(WxL)

Distributed by: